

RST® CLASSIC

SYSTEM OUTLET

For the standard compliant connection of power generation equipment up to 2000W.



The RST® system outlet is designed for the pluggable feed-in of energy from so-called "balcony power plants".

For a flush-mounted installation, the mounting frame is available, which is mounted in a commercially available flush-mounted box (depth at least 60 mm/ not included in the scope of delivery).

Alternatively, the mounting frame is installed in the surface-mounted housing.

In addition, for both types of installation, there is the device connection including the corresponding mating connector, which are available under separate part numbers.

Depending on the design of the system, the product range also includes connecting cables, a distributor and, last but not least, an end cap for the secure closure of slots that are not required.

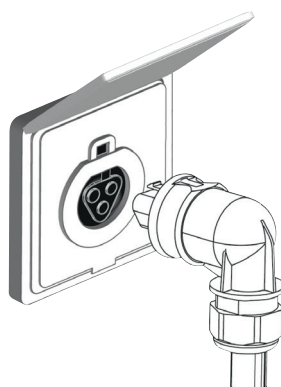

THE BENEFITS FOR YOU

- + Automatic, mechanical locking of the RST® CLASSIC connectors during mating
- + Disconnection of the locking mechanism using standard screwdrivers
- + Touch-proof contacts with male and female connectors, even in unplugged state



APPLICATIONS

- On facades in the garden for electric garden tools
- On house walls for connection of Christmas lights or advertising light boards
- For connection of mini solar system with module inverter (Micro-Inverter)



FEATURES

- Protection rating: IP44
- Approval of the RST® CLASSIC connector system:
 - IEC 61535: Installation connectors for permanent connection in fixed installations
- Suitable to accept all RST® CLASSIC built-in sockets (2- to 5-pole)
- Touch-proof

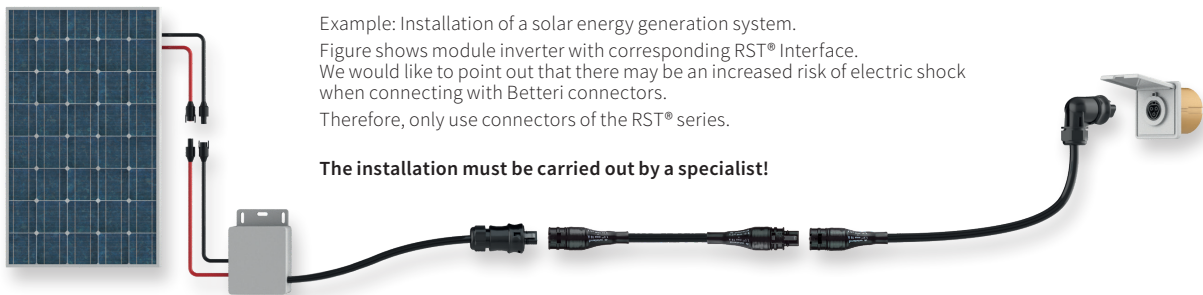

Example: Installation of a solar energy generation system.
Figure shows module inverter with corresponding RST® Interface.
We would like to point out that there may be an increased risk of electric shock when connecting with Betteri connectors.
Therefore, only use connectors of the RST® series.

The installation must be carried out by a specialist!

ORDER OVERVIEW

Name/type	Description	Part No.
1 Mounting frame RST Kit-Socket	RST 20/25 mounting frame for system socket, suitable for 2-/3-/4- or 5-pole M25 device connection	99.400.9999.7
2 Surface mount housing for mounting frame	Dimensions 81 x 81 x 43 mm, material plastic, color arctic white	99.404.9999.7
3 Device connection RST20i3F B2 M01 SW	RST20i3 Device connection M25, 3-pole, female part in spring-cage technology, application 250 V, 20 A, coding color black	96.031.1053.1
4 Connector RST20i3S S1 YR1 V SW	RST20i3 plug connector (90° angled), 3-pole, plug part in screw technology, application 250 V, 20 A, for cable diameter 6 - 10 mm, coding color black, housing color black	96.034.4053.1
5 Assembled cable RST20i3K-KFX 15 30 SW	RST20i3 Connecting cable female - male, 3-pole, assembled with heat shrink tubing, application 250 V, 16 A, cable type H07RN-F, length 3.0 m, conductor cross-section 1.5 mm², coding color black	99.405.9999.7
6 Assembled cable RST20i3K1BS 15 99 SW	RST20i3 Extension cable female - male, 3-pole, assembled with heat shrink tubing, application 250 V, 16 A, cable type H07RN-F, length 9.9 m, conductor cross-section 1.5 mm², coding color black	96.232.9930.1

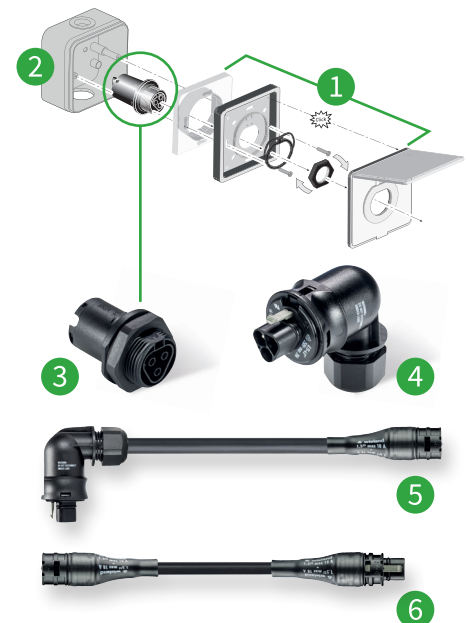

Wieland Electric GmbH
Brennerstraße 10 – 14 · 96052 Bamberg · Germany
Phone +49 951 9324-0 · info@wieland-electric.com

Represented in over 70 countries worldwide:

www.wieland-electric.com